

Installation Instructions & Use Recommendations

FMS Accessories – Opticom Control Module

These instructions must be read carefully and thoroughly **before** beginning work. FMS Solutions, LLC accepts no liability for damage caused by failure to observe the installation instructions or use recommendations.

Installation of this accessory does not change the factory specified load limits for the motorcycle.



The Opticom Control Module enables installers to configure the installation based on department use policy for emitter systems. The OCM provides precise triggering of the emitter modules based on operation of the front emergency lights, regardless of flash pattern / frequency. The OCM also provides a selectable manual pause function utilizing the fairing speaker mute switch (speaker mute function then disabled). The unit connects with the side stand to pause when "parked". Indicator light output is also provided for either Paused or Activated function using optional LED indicator lights. The user decides based on preference or department policy. When ordering, make selection regarding activation and indicator light wiring so that unit will be pre-set to those preferences.

Begin by attaching the OCM module to the underside of the radio box lid at shown at right using the special Velcro provided on the module.

Insert the blue/black wire with "Y" connection into the rear pod compartment through the existing hole.

Cable tie the OCM harness following the existing harness down to the floor of the radio box.



Remove the rear pod cover (two T25 Screws).

Unplug the 18-socket connector and release socket #1 (light blue wire) using the terminal release tool FMSA-EL-DUAC-RT.

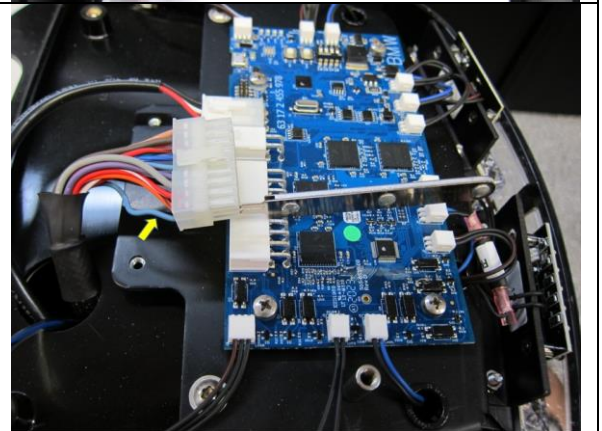
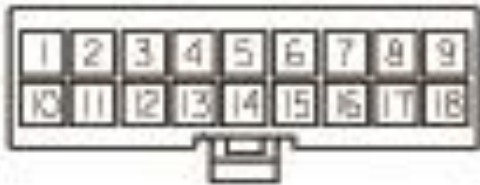

Insert the mating terminal from the blue / black wire into position #1, then connect the light blue wire to the mating connector. This connection taps the front light signal so that the OCM know when the emergency lights are activated. This signal is the primary signal to activate the OCM.

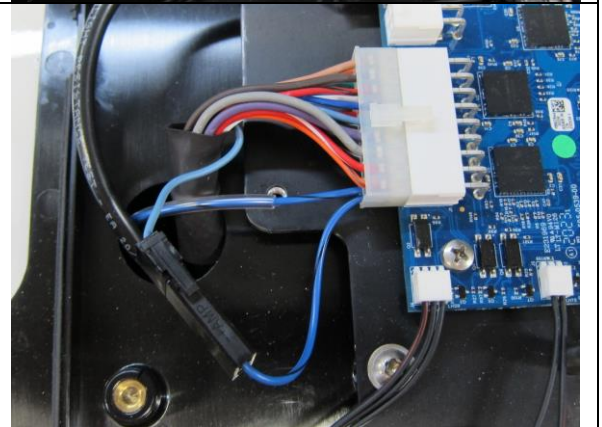

The Pause function is activated by the fairing speaker mute function / button. That is activated via the blue relay on the relay block.

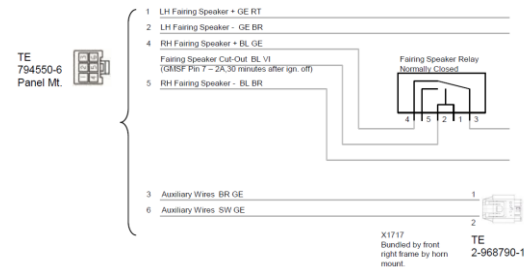

Release the relay block from the bracket by turning is counter-clockwise 1/8 turn and pull out. Remove both relays from the block.

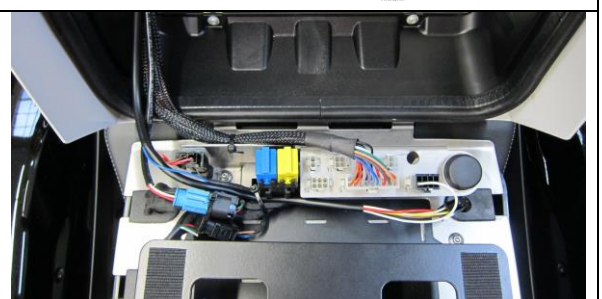

Release the relay block cover the lift-off the relay block. This reveals the connectors. Slide a rectangular release tool along side the connector and pull it out the bottom of the relay block.

Blue / red stripe wire.

Having released the desired wire w/terminal, assemble the relay block and install the relays again.

Heat shrink tubing is provided. Connect the wires as shown at right. The heat shrink will keep the connections from separating.

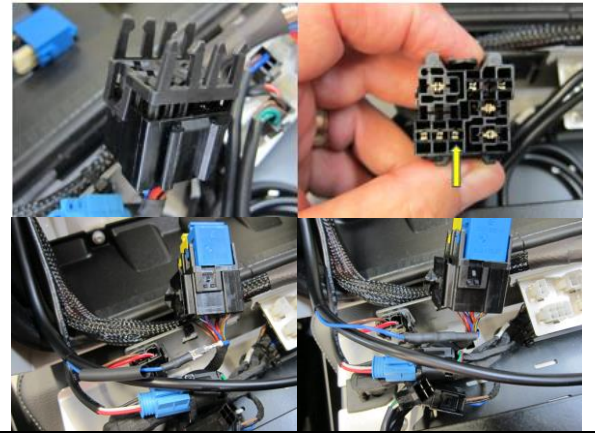

FMS Accessory Opticom Control Module (OCM) can be connected in several different ways.

1. Connect to the radio power plug #2.
2. Connection directly to the auxiliary battery using the connection extension.

Note that the OCM is fused at 5A. You can adjust that fuse size based on the specific model of emitter you are connecting.



Plug connections inside radio box of the R 1200 RT-P:

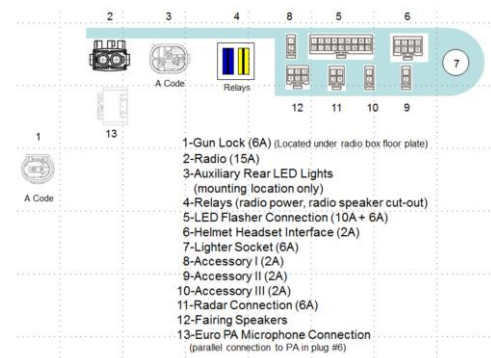

The second section of the OCM harness runs from the right corner of the radio box floor plate, up to the front of the motorcycle. This harness has the connection to the emitter as has a two-conductor plug to connect the optional LED indicator

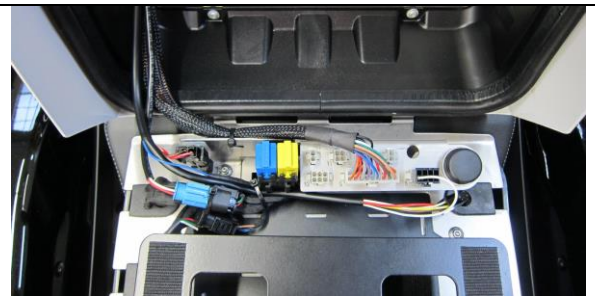

The side stand interrupt "Park" signal can be accessed through pin #5 on the helmet headset interface plug. Insert the white / grey wire terminal into position #5. This connection should be a ground signal when the side stand is extended.

See the BMW instruction for connecting the side stand harness, which is not connected from the factory as its placement conflicts with the production cradle. It is tied-back on the LH side.

https://aws-p-app1.bmwcenternet.com/bmw_mc_police/Media/Media.aspx?uid_media=330&uid_media_type=2

Side Stand Down Signal
Helmet Headset Plug #5

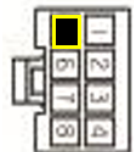

Cable tie the optional red LED indicator light to the front brake hose / harness as shown at right. This is an easy way to install the indicator. The LED indicator plugs into the harness.

The LED indicator is set to illuminate when the emitter is ON. If you want the LED indicator to illuminate when the emitter is Paused, you must swap the yellow wire on the OCM plug from pin 12 to pin 9.

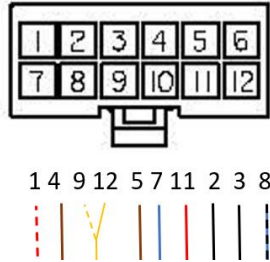

Indicator LED Connection



Select Fuse Size Based on Opticom Specification

Opticom Connection Diagram

1. Battery Positive +12v
2. Diode In from Opticom (anode)
3. Diode Out to Side Stand (cathode)
4. Battery Ground -
5. Ground
6. Ground
7. Pause Switch Input
8. Front Emergency Light Input
9. Opticom Pause Indicator LED
10. Not Used
11. Opticom Power Output
12. Opticom ON Indicator LED

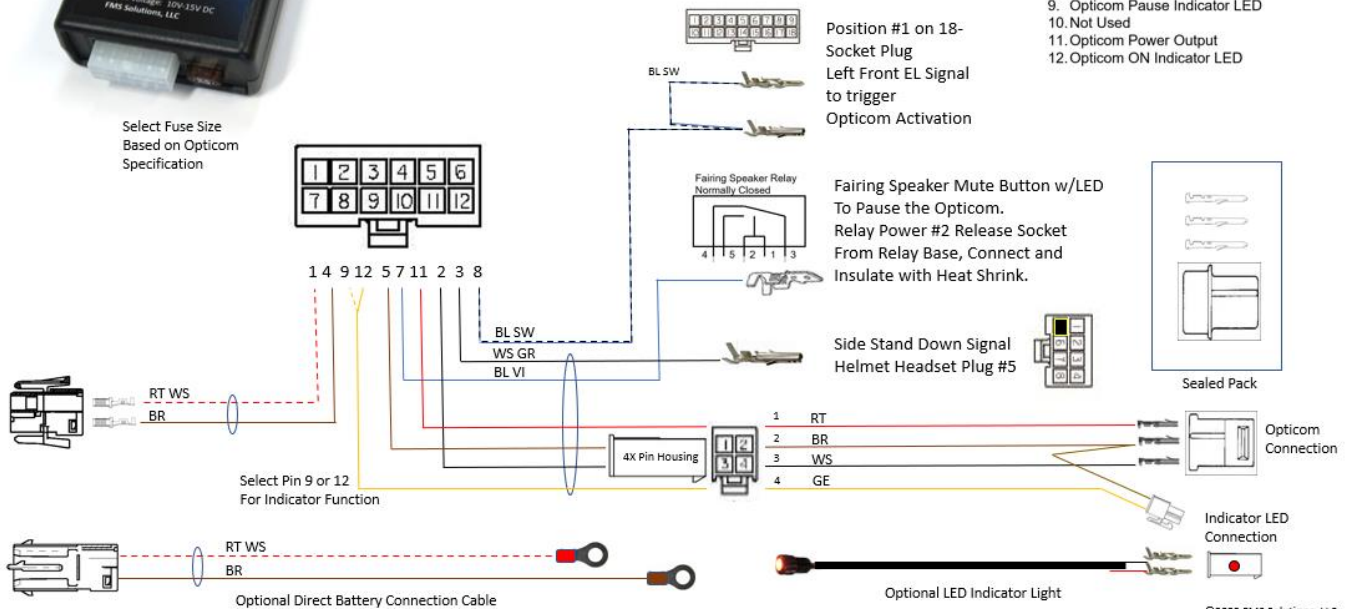

©2022 FMS Solutions, LLC

Remove seat bolster by loosening the two thumb nuts, then pulling the bolster forward. As the radio box unlock switch cable will still be connected, it is best to open the LH saddlebag and place the seat bolster in there so that the cable is not damaged.

Route the cable along the side that corresponds with the mounting location of the emitter you are using.

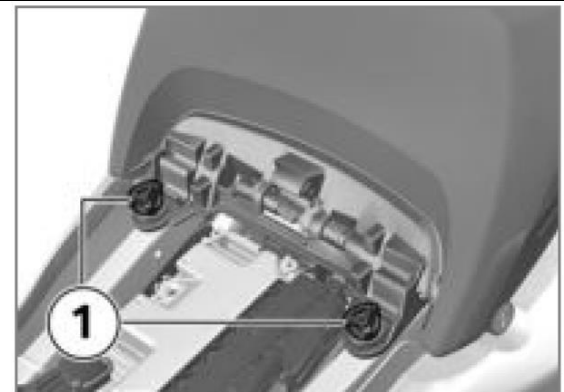

Removal of body panels

The steps below to best gain access for routing the wire cable is highly recommended. Consider if you have the requisite skills to do this work.

Remove the two screws inside the RH panel front radiator edge to remove the RH panel.

Note: Images from your BMW Rider's Handbook

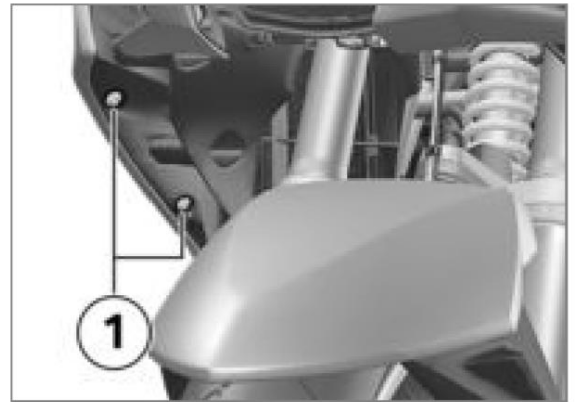

When removing and installing RH panel, note the tabs that are on the rear facing edge of the panel, which require the panel to be pulled-out at the front (rubber grommet prongs), then moved back to "unhook" the two tabs on the panel.

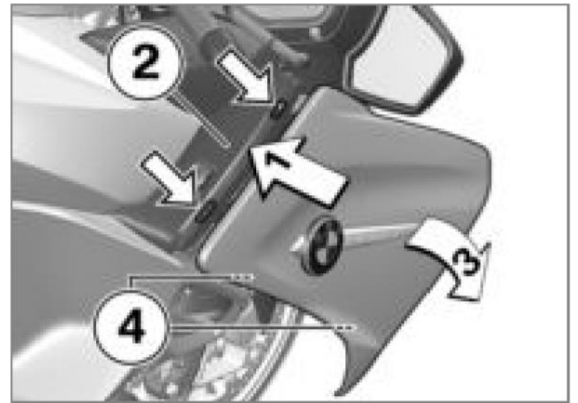

Be very careful not to damage the tabs when removing and installing RH panel.

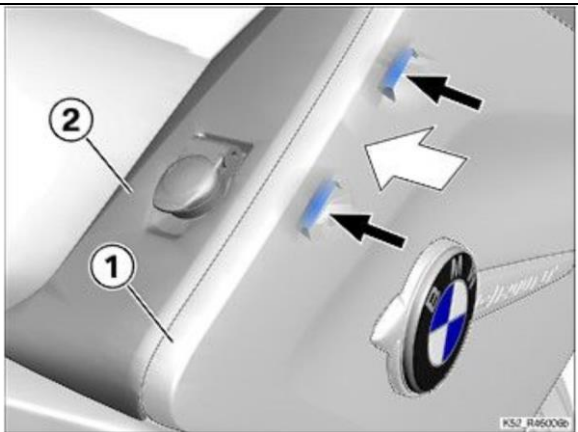

Remove and reinstall RH engine spoiler to gain access to fasteners to remove knee cover.

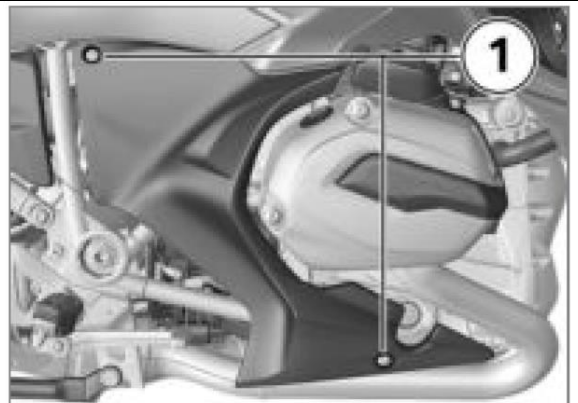

Remove and reinstall RH knee cover panel route wiring.

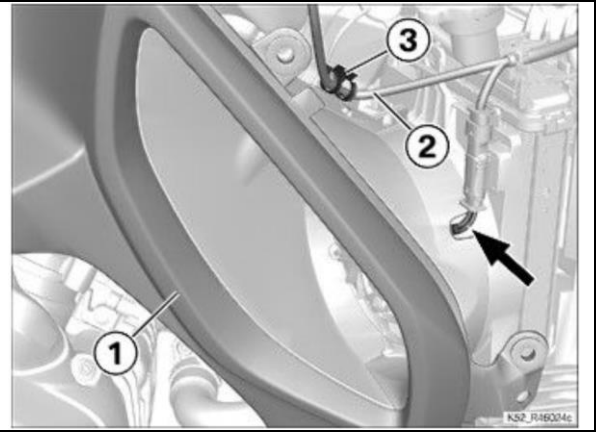

Note tabs on RH knee cover panel when removing and installing panel.

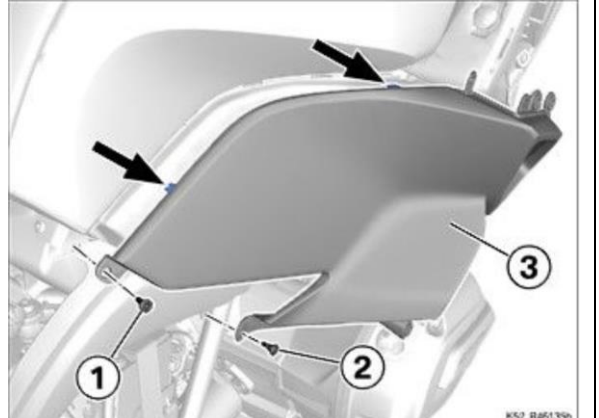

Note all screw locations when removing and installing panel.

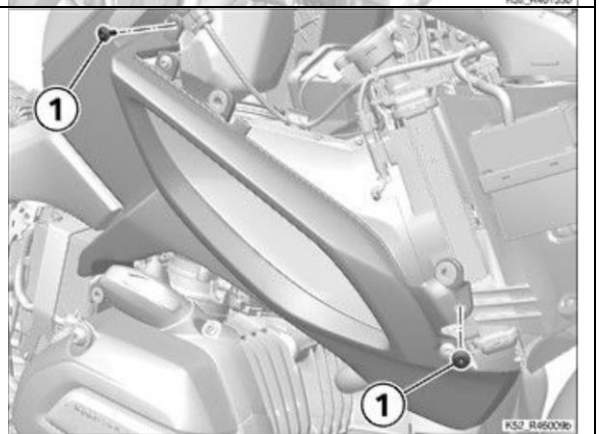

Feedback: Thank you for your purchase and we welcome your feedback as we too want to make every accessory exceed your expectations. Report any comments, suggestions, problems or concerns to FMS Solutions, LLC at info@fmsaccessories.com .

FMS Solutions, LLC Limited Warranty

FMS Solutions, LLC warrants to the first retail purchaser of new FMS Accessory products, to be free from defects in materials or workmanship, for a period of three (3) years from the original date of purchase as noted on the FMS Solutions, LLC invoice or original dealer invoice, except for paint and powder-coated finishes, which are warranted for the first 12 months only. LED lights from Fenix, Inc., Code 3, Inc. and Littlite are covered for 5 years by their manufacturer's respective warranties – processed through FMS Solutions, LLC.

This warranty extends only to the FMS accessory and does not include: damage caused by accidents or abuse; incorrect installation; labor to diagnose, remove, repair or replace; any consequential damage or loss of use. Any FMS Accessory suspected of being defective should be returned to FMS Solutions, LLC along with a copy of proof of purchase and warranty request form available on the FMS website. FMS Solutions, LLC will determine if the FMS accessory has a warrantable defect, and if so, will repair or replace the item and return it to the sender without charge. The decision to repair or replace said item is solely the prerogative of FMS Solutions, LLC.

Note: Police motors can operate in a very rough environment since police motors are a "tool". They can be dropped, knocked-over, etc. without concern as the officer has a job to do and determines what is necessary at any given moment. Warranty is for defects in materials or workmanship. Therefore, the ability of an item to become broken or damaged does not mean it is warranty ... it just means it is broken or damaged and in need of repair or replacement. No manufacturer warrants their products to be indestructible. Any questions should be directed to info@fmsaccessories.com .

